

GSA DATA REPOSITORY**Kinematic models of fluvial terraces over active detachment folds: constraints on the growth mechanism of the Kashi-Atushi fold system, Chinese Tian Shan**

Scharer, K. M., Burbank, D. W., Chen, J., Weldon, R. J. II
Geological Society of America Bulletin, 2006

Figure GSADR1. Kinematic models of terrace deformation by limb rotation during base level changes. The geometry of the pre-growth beds is shown by grey and white layers, the terraces are shown by black lines. Boxes on the ends of cross sections reflect actual shortening at each stage. Black circles track points on the terrace through the deformation. (A) Pre-existing fold with 120° interlimb angle. (B) Shortening reduces the interlimb angle to 90° and tilts and uplifts terrace x. (C) Fluvial aggradation between deformation of terrace x and development of terrace y results in older terraces that are shorter and intersect the younger terrace. The younger terrace (y) must be a fill terrace. Where buried, terrace x is shown by dashed line. (D) River incision between deformation of x and development of the y results in a vertical separation of the terrace treads.

Figure GSADR2. Kinematic models of terrace deformation by hinge migration during base level changes. (A) The fold exists before a terrace is cut across it, with hinges at positions 1 and 2. (B) Hinge 2 migrates to position 3, lengthening the fold limb. Material passes through hinge 3 while hinges 1 and 2 remain passive. The terrace and the pregrowth beds follow the same particle path, shown by the black circles moving into and up the limb. (C-D) After (B), fluvial incision lowers the river level before hinge 4 migrates. In (C), the hinge migrates towards the syncline, which separates the terraces along their inclined sections. In (D), the hinge migrates towards the anticlinal axis. The resulting terrace geometries are very similar to the case with no incision (Figure 4G) but show vertical separation on the flanks of the fold. (E-F) After (B), aggradation before hinge 4 migrates buries the earlier river profile. (E) Migration of the hinge towards the synclinal axis causes the inclined portion of the older terrace to terminate into the level segment of the younger terrace. The original terrace level indicated with the dashed line

and open circles show the particle path of the buried horizon. (F) If anticlinal hinge migration occurs, a ziggurat geometry is created and the outermost inclined portions of older terrace are truncated by the modern river profile.

GSADR3. Standard graphics programs can be used to model simple geometric changes such as shear, rotation, and translation that occur during kink-band style fault-related folding. Our models are particularly suited for this approach, because they assume bed-parallel shear within the upper units and heterogeneous shear lower in the stratigraphy (which is assumed to cause no effect in the upper units), and finally, no out-of-plane strain. Furthermore, we used the models to understand geometric and kinematic relationships, not details of the actual physical processes. Figures GSADR3A and GSADR3B illustrate how we used a graphics program (Adobe Illustrator 10.0) to evaluate the effect of limb rotation and hinge migration, respectively, on a horizontal datum (e.g. a fluvial terrace). The illustrations are guides only, and assume familiarity with the layout and tools of Adobe Illustrator. The Object/Transform tools and cut, group, and align functions are used regularly.

Limb rotation, constant limb length

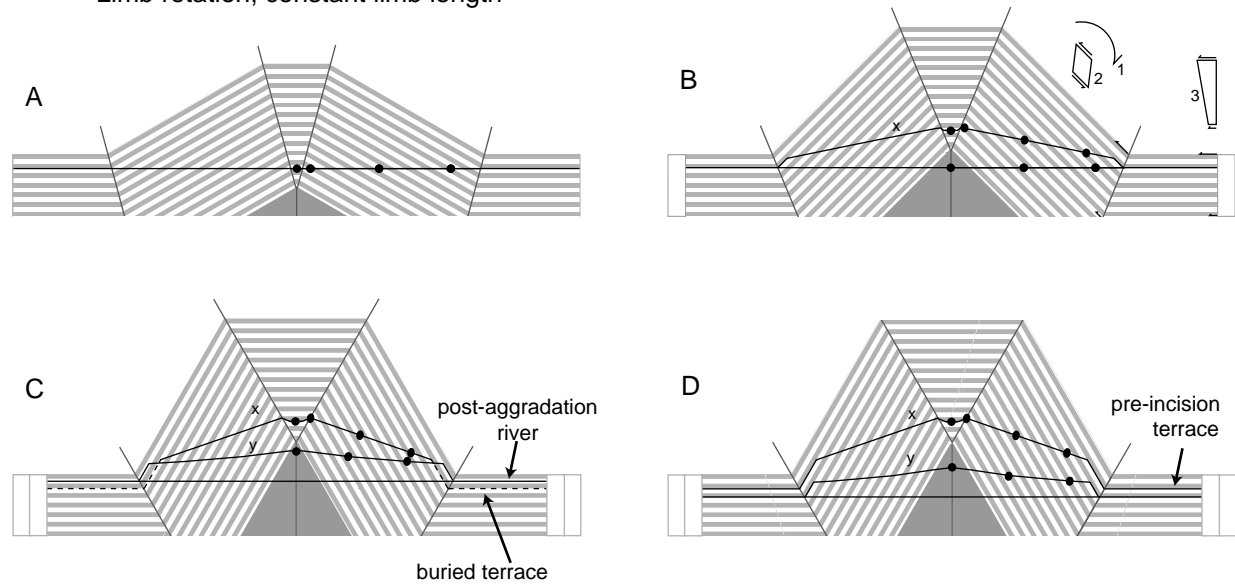

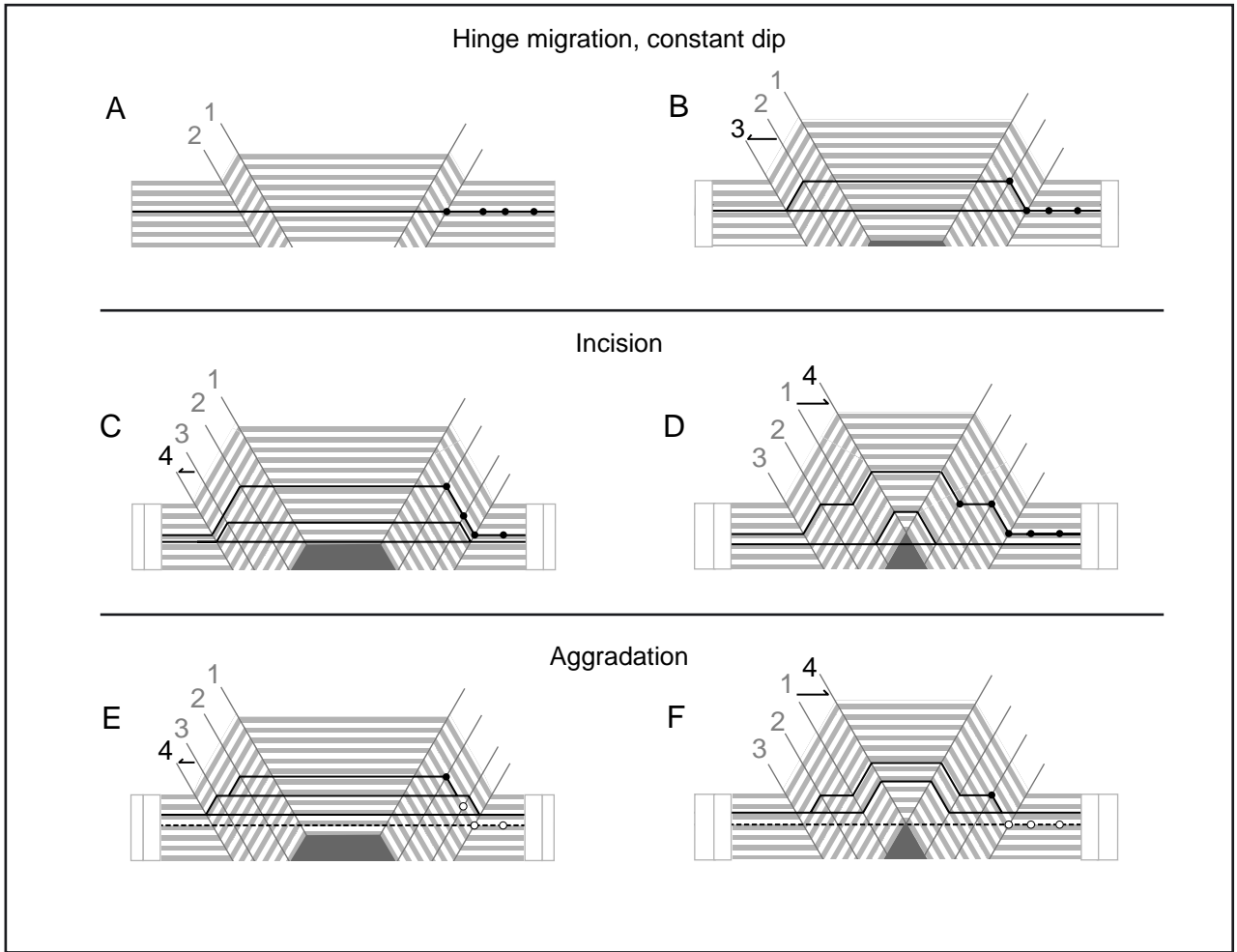

GSADR3A - Limb Rotation

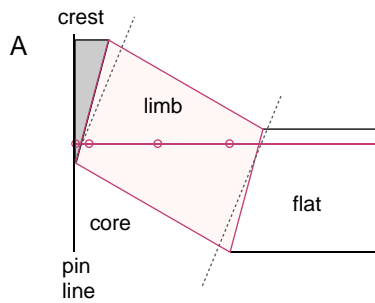

A. Create preexisting topography. Establish limb thickness and length (purple trapezoid). Create terrace, and mark a few locations along limb to track (thick purple line and circles). Establish a pin line (we used the center). Dashed lines show location and angle of future axial surfaces; their angle must bisect the resulting kink bands and thus their orientation is determined by the amount of limb rotation that will occur over this time step. Grey region shows original width and area of crest. We allowed heterogeneous shear within the core based on local stratigraphy. Ignore outer flat section until final step.

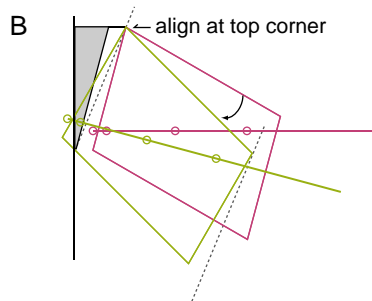

B. Group the limb, terrace, and marks (purple), and rotate (here 15 degrees clockwise, to create green orientation). Realign with original at top corner (intersection of the new axial surface and the crest of the fold, indicated with arrow).

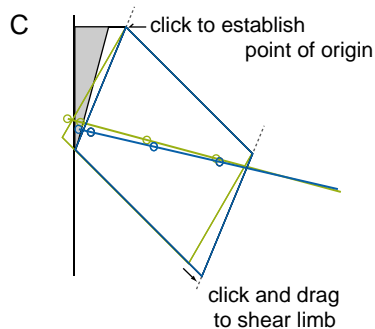

C. The limb now must be sheared, so that the angle between the kink bands is bisected by the axial surface. To do this without changing the limb thickness use the Shear Tool. Rather than use the default "point of origin," click one corner of the limb to establish a new point of origin (we use the top left corner). Move mouse to a different corner, in this case the bottom-right corner, then click and drag to align edges with desired axial surface orientations while being careful not to alter the limb thickness (blue).

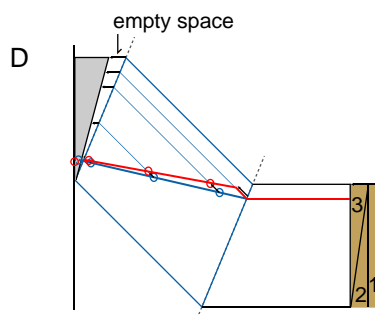

D. Now the limb has the correct shape, but the space between grey region at crest and new axial surface is empty. Fill this gap by translating the beds by layer-parallel shear, i.e., translating points within any panel parallel to the outer shape of that panel. Measure the amount of shear required to fill the empty space (arrows in empty space), and translate the terrace and marks by the appropriate amount but parallel to the limb. We show the amount of movement with black arrows along the thin blue lines. The result is to move the terrace marks from the blue position to the final red position. The movement should restore the mark on the pin line to its original height.

Finally, align flat (from A) with new limb. The total shortening (tan box) results in no net shear of the limb, because it is a combination of (1) parallel shortening resulting from decreasing the wavelength of the fold, (2) rotation causing more shortening towards the base of the panel, which is balanced by (3) more shear at the top of the panel, which is required to fill the empty space at the crest of the anticline.

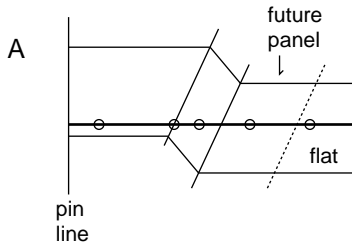

A. Create preexisting topography with axial surfaces that bisect angle between neighboring kink panels. Create terrace, and mark a few locations along terrace to track (thick black line and circles). Establish a pin line (we used the center). Dashed line shows outer position to which the active axial surface will migrate, and thus establishes the dipping kink panel that will be created in this time step. The width of the future panel (w) determines the height of growth (h) and amount of shortening (s) that will take place in this interval.

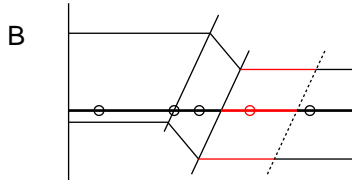
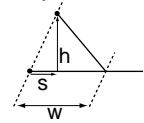

B. Migrating the hinge away from the core causes the kink panel to instantaneously rotate into its new angle. This is achieved by cutting all lines where they cross the dashed axial surfaces (red segments).

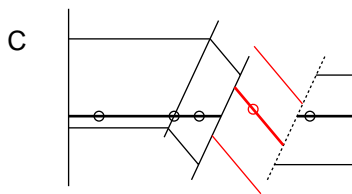

C. Group the markers with the terrace segment. Rotate all objects within the future panel to new angle, here 50 degrees. Using the Object/Transform/Transform Each option will retain the correct panel thickness.

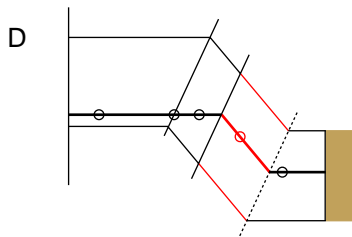

D. Align newly rotated segments with core, and then move flat into place. Total shortening shown by tan box. Note how final terrace shape shows the location of the old axial surface as a bend within the fold limb.

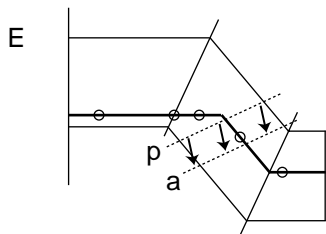

E. To create a kink panel with a different orientation within an existing panel, identify the location of a new passive (p) axial surface with an orientation that bisects existing kink panel and panel that will be created in this time step. The active axial surface (a) will sweep through limb (illustrated with arrows). The location of the active axial surface may be determined by the amount of shortening or uplift desired in this time step.

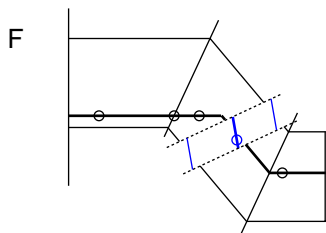

F. As in B and C, cut and rotate new kink band segments (blue).

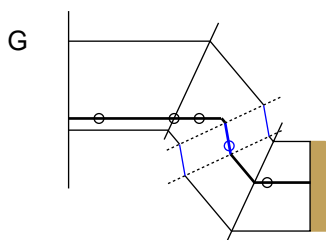

G. As in D, align terrace blue segments, realign flat (and lower, cut portion of original limb) with active axial surface. Shortening from E-G shown by tan box.